



Air Water Heat Pump for outdoor installation

- Provides, in conjunction with the EcoEI, heating and DHW down to outdoor temperatures of -15°C
- Equipped with a built-in control system to prevent freezing of the evaporator
- Easy to install, placed outdoors
- Economical operation all the year round
- High efficiency
- A wide field of application
- Scroll-compressor with superior performance during winter-time.
- Built-in soft starter

The EcoAir is an air source heat pump which, integrated with an EcoEI, provides a complete heat pump solution for private houses and smaller properties.

The EcoAir can also be used in conjunction with a new or existing heating boiler.

The heat pump is an air/water unit designed to extract low temperature heat from the surrounding air.

A fan forces the air over the finned evaporator which collects energy for transfer to the heating system.

The EcoAir is placed outside but usually close to the building being heated and has a 'footprint' of 500mm x 1200mm and, depending on output, varies from 1040mm to 1280mm in height.

As a ground loop is not required the EcoAir is simple, fast and inexpensive to install.

An internal control system prevents icing of the evaporator by periodic heating. The water produced drains from the base of the unit.

	Elect. boiler EcoEI		Heat pump / outdoor unit EcoAir				Heat pump control system EcoLogic	
Model	1800/1550		105	107	109	111	System without mixing valve	System with mixing valve
Main Measurements mm	600 x 624 x 1812/1562		1190 x 1040 x 407		1190 x 1280 x 407		290 x 225 x 95	
Weight kg	170/155		100	105	135	140	Included in delivery Ecologic	
Water volume boiler litres	223		-	-	-	-		
DHW, type/volume litres	Fin/5.7		-	-	-	-		
Max op press/temp bar/°C	2.5/100		-	-	-	-		
Electrical data	230V 1ph 400V 3ph		230V 1ph 400V 3ph	- 400V 3ph	230V 1ph 400V 3ph	230V 1ph 400V 3ph	System without mixing valve	System with mixing valve
Output kW 230V 1ph 400V 3ph	6 + 6 9 + 6		6+HP 9+HP	6+HP 9+HP	6+HP 9+HP	6+HP 9+HP	-	Flow valve
Output limit kW	1.5/step		-	-	-	-	-	Bypass valve
Internal pressure guard	Yes		-	-	-	-	Outdoor sensor	
Emitted output 0/50°C kW	-		4.8	6	7.3	8.2	Room sensor	
COP at 0/50°C	-		2.7	2.65	2.6	2.55	Flow gauge	
Emitted output 2/35°C kW	-		5.35	6.6	8.12	9.1		
COP at 2/35°C	-		3.55	3.45	3.65	3.6		
Type of compressor	-		Scroll	Scroll	Scroll	Scroll		
Refrigerant R407 C	-		1.20 kg	1.20 kg	2.20 kg	2.20 kg		
Fan Speed *) kW	-		0.12 / 0.10	0.12 / 0.10	0.14 / 0.10	0.14 / 0.12	*) The speed alters automatically by thermostat	
Air quantity m ³ /h	-		2400/2300	2400/2300	3000/2500	3000/2500		
Cover	Stainless steel / galvanised enamelled steel plate / sound absorbing ABS							

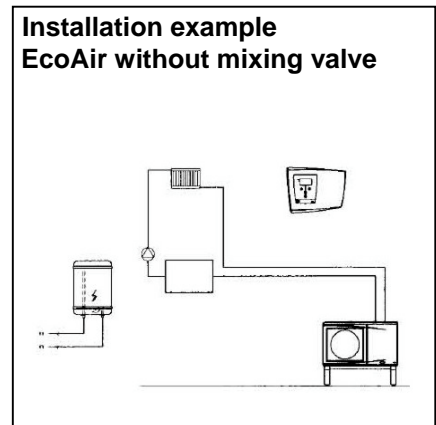
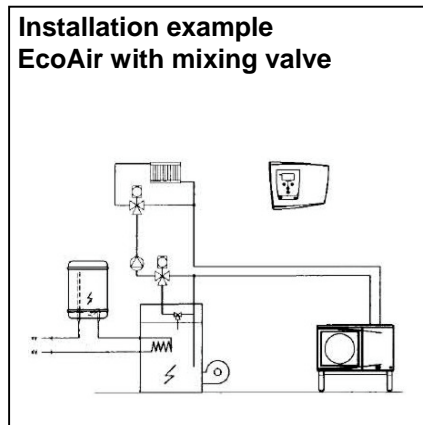
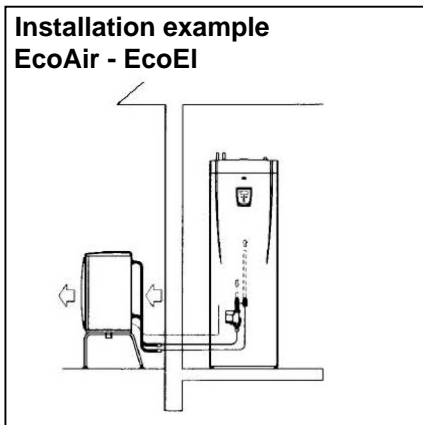

Note: For more connection alternatives, see leaflet for EcoLogic.

Noise installation data EcoAir (dBA)

From the front	Distance			
	1 metre	4 metres	10 metres	15 metres
EcoAir 105 and 107 fan speed high/low	56 / 50.5	45.5 / 41	38.5 / 35	36 / 32.5
EcoAir 109 and 111 fan speed high/low	57.5 / 52.5	48 / 44	40 / 36	36 / 33
45° angle	1 metre	4 metres	10 metres	15 metres
EcoAir 105 and 107 fan speed high/low	53.4 / 49	44.5 / 40.5	37.5 / 35.5	35 / 34
EcoAir 109 and 111 fan speed high/low	55 / 51	47.5 / 42	39.5 / 38.5	36 / 35

Measurements Eco Air 105 / 107 / 109 / 111

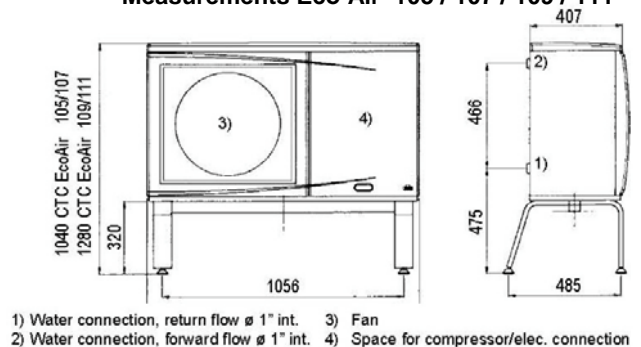

Subject to alterations in design



NU-WAY LIMITED, P.O. Box 1, Vines Lane, Droitwich, Worcestershire, WR9 8NA
Tel: +44 (0)1905 794331 Fax: +44 (0)1905 794017